

THIS DRAWING IS UNPUBLISHED. RELEASED FOR PUBLICATION .19
 © COPYRIGHT 19 BY AMP INCORPORATED. ALL INTERNATIONAL RIGHTS RESERVED.

REVISIONS									
LOC	DIST	P	F	ZONE	LTR	DESCRIPTION	DATE	APPD	
G	14				D	REV & REDWN PER 0720-0055-94 & 0720-0124-94	27JUL94	✓ ^{CS} DAP	

METRIC
 DIMENSIONS LISTED IN mm [INCHES]

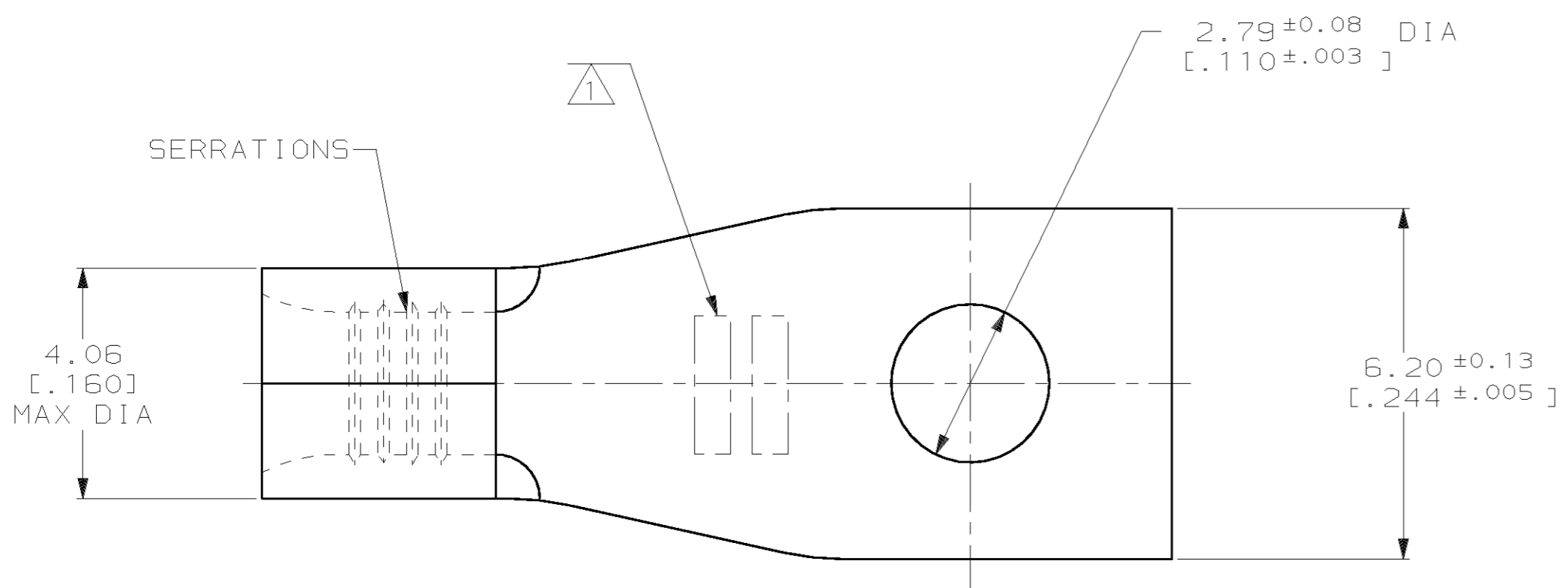

AMP WIRE RANGE	UL E13288 Listed
16-14 AWG STRANDED	16-14 AWG STRANDED
CS LR7189 Certified	MILITARY P/N AND CLASS
NOT CERTIFIED	NOT APPLICABLE

⚠ STAMP AMP 16-14* APPROX AS SHOWN

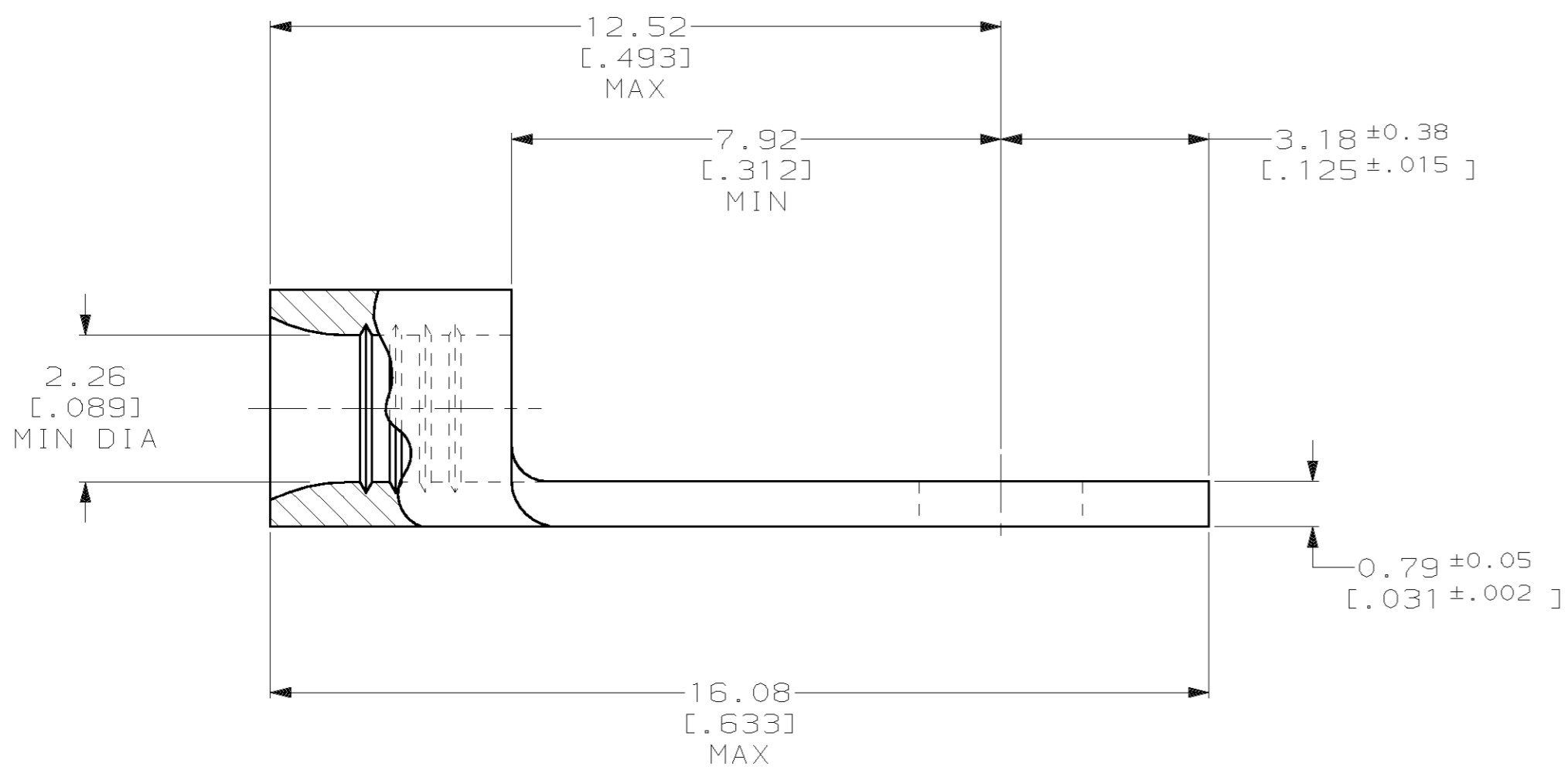

AMP INCORPORATED CUSTOMER SERVICE SYSTEMS		MAX RECOMMENDED OPERATING TEMPERATURE: 170°C MAX	DO NOT SCALE PRINT. UNLESS SPECIFIED DIMENSIONS IN mm [INCHES] TOLERANCES ON: 2 PLC DEC ± - 3 PLC DEC ± - ANGLES ± -	DR 05JUL94 DK SCHRUM	5000 ON TAPE, REEL 2-35129-1
FOR ADDITIONAL PRODUCT INFORMATION OR COPIES OF DRAWINGS AND TECHNICAL DOCUMENTS	PRODUCT INFORMATION CENTER 1-800-522-6752	VOLTAGE RATING: NOT APPLICABLE	MATERIAL COPPER PER ASTM B-152 ANNEALED	CHK 08AUG94 DA PATTERSON	- LOOSE PIECE 35129
FOR APPLICATION TOOLING INFORMATION	TOOLING ASSISTANCE CENTER 1-800-722-1111	WIRE CROSS SECTIONAL AREA RANGE: 1.04-2.62mm ² [2,050-5,180] CIR MILS STRANDED	FINISH TIN PLATE 0.00254 [.000100] MIN THK PER MIL-T-10727	APPD 08AUG94 CH KULYNYCH APPD 08AUG94 JL MECKLEY PRODUCT SPEC -	QTY PACKAGE TYPE PART NO
FOR ORDER ENTRY	1-800-526-5142	THIS DRAWING IS A CONTROLLED DOCUMENT FOR AMP INCORPORATED. IT IS SUBJECT TO CHANGE AND THE CONTROLLING ENGINEERING ORGANIZATION SHOULD BE CONTACTED FOR THE LATEST REVISION.		AMP Incorporated Harrisburg, PA 17105-3608	
				NAME TERMINAL, RECTANGULAR TONGUE, BUDGET	
				APPLICATION SPEC -	SIZE CAGE CODE DRAWING NO C 00779 C=35129
				WEIGHT -	SCALE 10:1 SHEET 1 OF 1